

# H4000 Woltmann cold water meters

The accurate, robust meter



# H4000 Woltmann cold water meters

The H4000 is a Woltmann-type meter designed for measuring bulk flows of cold potable water for revenue billing in commercial or industrial applications and distribution system monitoring.

## Key features

- Inductive register for improved output performance and security
- Extended low and high flow performance
- Suitable for forward and reverse flow metering
- Robust shroud and copper can register for long-life and clear readability
- Longer wear life for optimum accuracy
- Exceeds Class B specification in forward direction and for sizes up to 150mm in reverse direction

Available in ten sizes for flow rates between 0.35 m<sup>3</sup>/h and 2000 m<sup>3</sup>/h, the H4000 operates at temperatures up to 50°C and a maximum working pressure of 16 bar. Accuracy is maintained in both forward and reverse flow, and the product offers the benefits of inductive-based pulse communications technology. The meter complies with all relevant international quality standards, substantially exceeding ISO4064 BS5728 Class B specifications for forward flow installations in horizontal, vertical and inclined pipelines.

## Reverse flow metering

Available in sizes up to 150mm, reverse flow metering aids network management and ensures accuracy in revenue billing applications.

## Robust construction

Like all Elster meters, the H4000 is manufactured from the highest quality materials for maximum resistance to wear and corrosion. Meter body and cover are epoxy powder coated for protection in all environments. Thrust pads and stub spindles are manufactured in tungsten carbide and jewelled rotor bearings are used for maximum wear life. All wetted materials are UK WRAS approved against health risk.

## Flexible installation

Installation can be in horizontal, vertical and inclined pipelines. The H4000 also achieves good performance in abnormal installations.

## Intelligent metering

Fully compatible with Elster's Emeris range of intelligent meter reading systems, H4000 can provide even more vital management information to assist with effective distribution management, reduce water losses from leakage and improve customer service. When combined with the Emeris TRC600 unit (pictured below), a range of intelligent features including leakage alarms, datalogging and tariffs enables a complete metering system that addresses the efficiency objectives for water providers.



## Reliable connectivity

The H4000 uses an inductive register to deliver enhanced communications performance and tamper proof security, offering protection against fraud. The H4000 is compatible with the Emeris PR7 inductive pulse transmitter, and offers both high and low speed bi-directional pulse capabilities as standard. The PR7 is fully compatible with other common ancillary devices including dataloggers and AMR systems.

When used in conjunction with H4000's optional integrated pressure port, this allows convenient logging of flow-rate and pressure simultaneously for effective water resource management.

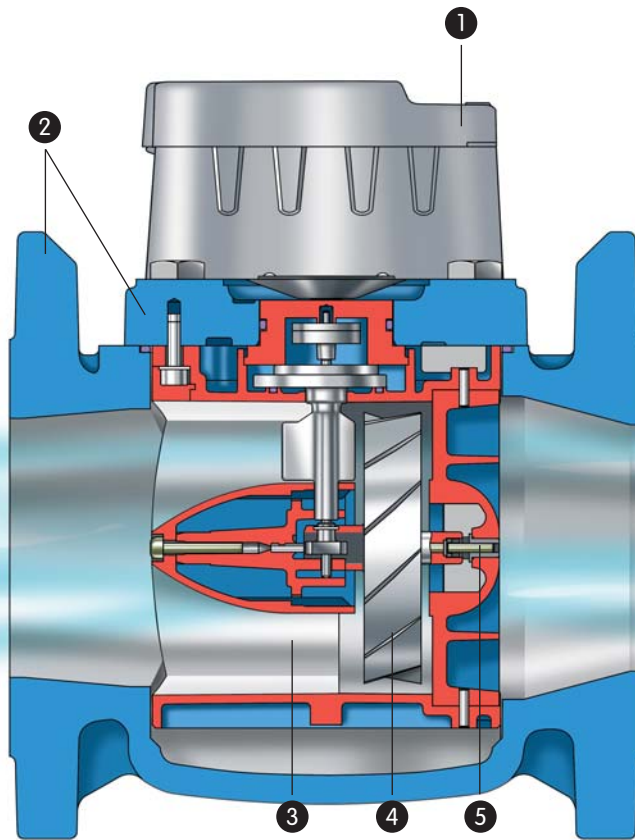

## C&I inductive register

- 1 Inductive target for bi-directional pulse communications
- 2 Star tell-tale for easy-to-see flow detection
- 3 Easy to read display – 6 figure display for sizes 40mm to 125mm, 7 figure display for sizes 150mm to 300mm

- 1 Tamperproof shroud and robust lid
- 2 Epoxy powder coated body and cover
- 3 Maximum length flow straightening vanes
- 4 Low mass rotor with hydrodynamic thrust relief
- 5 Hard surface rotor bearings – tungsten carbide and synthetic sapphire

